

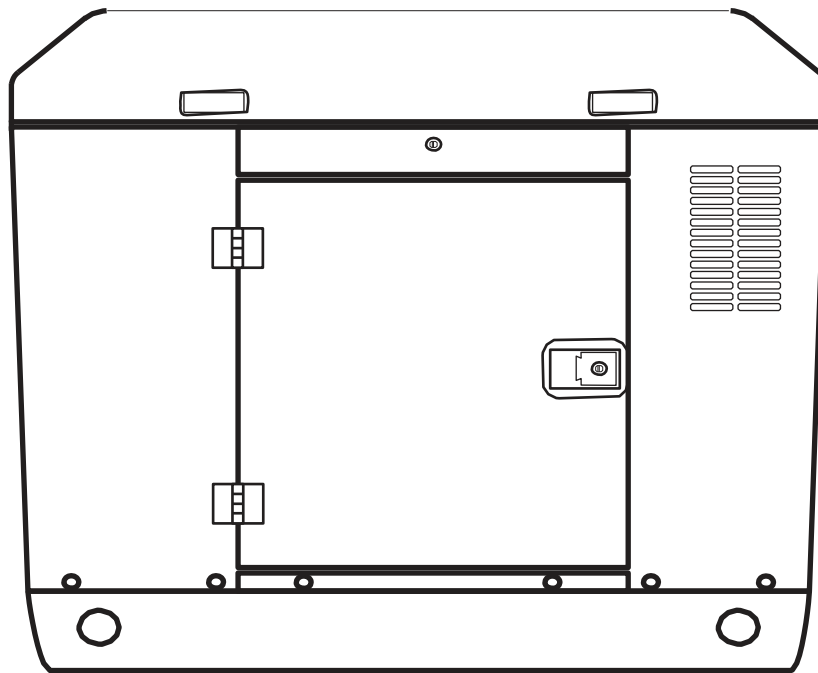

# **Promate**<sup>®</sup>

## **DIESEL GENERATOR**



**PM13000D ES (OPEN)**

**PM13000D ES (SILENT)**

# **OPERATOR MANUAL**

# FOREWORD

Thank you for purchasing our product. This operator manual is for proper handling, minor checking and maintenance of the generator. Before using your generator: Please read these instructions completely and carefully in order to make the best use of it as well as operate it safely. Due to constant efforts to improve our products, certain procedures and specifications are subject to change without notice, if you have any questions, please contact Promate Service.

## CONTENTS

|   |    |
|---|----|
| 1. Safety Precautions .....                             | 1  |
| 2. Generator Set Assembly Components .....              | 2  |
| 2.1 PM13000D ES(Open) Components .....                  | 2  |
| 2.2 PM13000D ES(Open) Components .....                  | 2  |
| 3. Inspection Before Operation .....                    | 3  |
| 3.1 Checking and selecting your engine oil .....        | 3  |
| 3.2 Selecting and checking the fuel .....               | 4  |
| 3.3 Checking the battery .....                          | 4  |
| 4. Starting Your Generator .....                        | 5  |
| 5. Operating Your Generator .....                       | 5  |
| 5.1 Operating your generator .....                      | 5  |
| 5.2 Checks during operation .....                       | 5  |
| 5.3 Loading your generator .....                        | 5  |
| 6. Stopping Your Generator .....                        | 6  |
| 7. Periodic Checks And Maintenance .....                | 7  |
| 7.1.a Changing engine oil (PM13000D ES) .....           | 8  |
| 7.1.b Changing engine oil (PM13000D ES Silent) .....    | 8  |
| 7.2 Cleaning the oil filter .....                       | 9  |
| 7.3 Cleaning and changing the air cleaner element ..... | 9  |
| 7.4 Long term storage & transport .....                 | 9  |
| 8. Specifications .....                                 | 10 |
| 9. Service Information .....                            | 11 |

# 1. Safety Precautions

Please make sure you review each precaution carefully.



## **⚠️ WARNING** OTHER SAFETY PRECAUTIONS

- Parts become hot when the generator runs. Take care not to burn yourself.
- The muffler and other engine parts become very hot while the engine is running or just after it has stopped. Operate the engine in a safe area and keep children away from the running engine.

## **⚠️ WARNING** EXHAUST PRECAUTIONS

- Never inhale exhaust gas. It contains carbon monoxide, a colorless, odorless and extremely dangerous gas which can cause unconsciousness or death.
- Never operate the generator indoors or in a poorly ventilated area, such as tunnel, cave, etc. Exercise extreme caution when operating the generator near people or animals.
- Keep the exhaust pipe clear of foreign objects.

## **⚠️ WARNING** REFUELING PRECAUTIONS

- Refuel in a well-ventilated area. Make sure the generator is off before refueling. Take care not to overfill the tank. If fuel is spilled, wipe it away carefully before starting the engine.

## **⚠️ WARNING** WHEN CHARGING THE BATTERY

- Battery electrolytes contain sulfuric acid. Take care that your eyes, skin, and clothing do not come in contact with the electrolytes. If eyes are accidentally exposed, flush thoroughly with water and get immediate medical attention.
- Charge the battery in a fully ventilated place.
- Make sure battery polarity is correct.

## • **Where to use the generator:**

Do not use it near flammable materials. Keep it at a 1-meter distance from buildings or any flammable surfaces.

## • **While the generator is running:**

- Do not tip or move.
- Do not cover it with a box or enclose it with a fence.
- Never unscrew the dipstick when using the generator set, you can get scalded by ejected oil.
- Do not touch the generator if either your hands or the generator is wet.

- To avoid an electric shock, ground the generator from the ground terminal.

- Avoid using the generator in a place where the ground is not firm.

- Never connect the generator to the wiring of a power company.

## 2. Generator Set Assembly Components

### 2.1 PM13000D ES (Open) Components

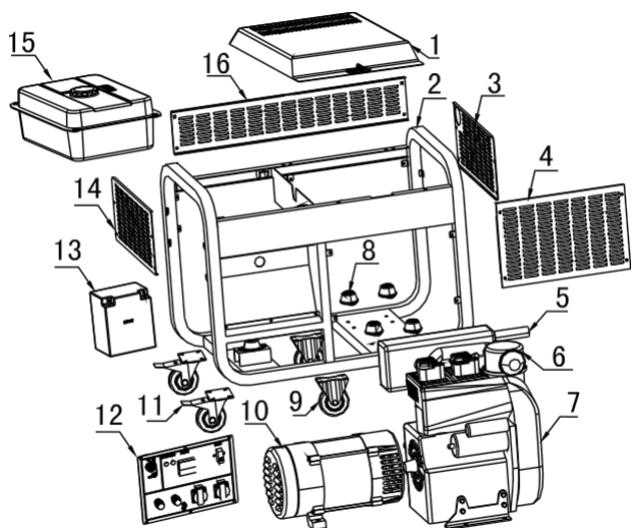

| Item | Description          | Qty |
|------|----------------------|-----|
| 1    | Top cover            | 1   |
| 2    | Frame                | 1   |
| 3    | Engine side cover    | 1   |
| 4    | Front cover          | 1   |
| 5    | Muffler assembly     | 1   |
| 6    | Air cleaner assembly | 1   |
| 7    | Engine               | 1   |
| 8    | Shock absorber       | 6   |
| 9    | Lock wheel           | 2   |
| 10   | Alternator           | 1   |
| 11   | Wheel                | 2   |
| 12   | Control panel        | 1   |
| 13   | Battery              | 1   |
| 14   | Motor side cover     | 1   |
| 15   | Fuel tank            | 1   |
| 16   | Back cover           | 1   |

### 2.2 PM13000D ES (Silent) Components

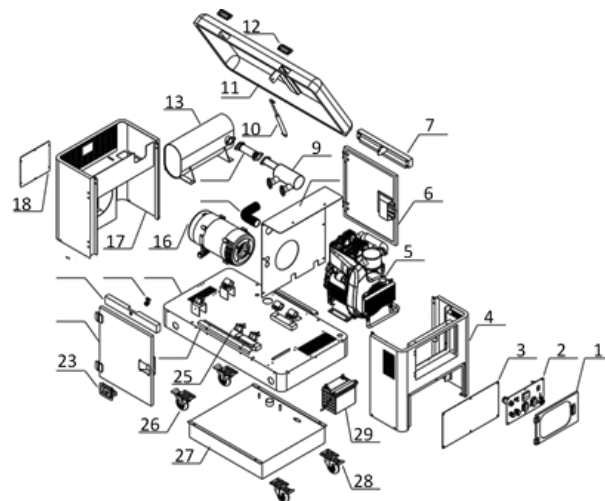

| Item | Description                  | Qty |
|------|------------------------------|-----|
| 1    | Control door assembly        | 1   |
| 2    | Control panel assembly       | 1   |
| 3    | Engine maintenance board     | 1   |
| 4    | Front cover plate            | 1   |
| 5    | The engine assembly          | 1   |
| 6    | Right soundproof Door        | 1   |
| 7    | Right soundproof Door        | 1   |
| 8    | Inlet separator              | 1   |
| 9    | First stage silencer         | 1   |
| 10   | Gas spring                   | 1   |
| 11   | Upper cover                  | 1   |
| 12   | Flip button                  | 2   |
| 13   | Secondary muffler            | 1   |
| 14   | Muffler connecting pipe      | 1   |
| 15   | Nylon hose                   | 1   |
| 16   | The alternator assembly      | 1   |
| 17   | Rear cover plate             | 1   |
| 18   | Alternator maintenance board | 1   |
| 19   | Underpan                     | 1   |
| 20   | Flip lock                    | 1   |
| 21   | Left cover beam              | 1   |
| 22   | Left soundproof door         | 1   |
| 23   | Soundproof door lock         | 2   |
| 24   | Underpan protective plate    | 2   |
| 25   | Shock absorber               | 6   |
| 26   | Universal wheel              | 2   |
| 27   | Fuel tank assembly           | 1   |
| 28   | Direction wheel              | 2   |
| 29   | Battery                      | 1   |

### 3. Inspection Before Operation

Place the generator on a firm and flat surface.

#### 3.1 Checking and selecting your engine oil

- The engine can be damaged if operated with insufficient lube oil. It is also dangerous to fill with too much lube oil because a sudden increase in engine rpm can cause combustion. Always check the lube oil level before starting the engine and refill if necessary.
- Pull out the oil gauge, wipe it with a rag or paper towel then dip it into the filter neck and pull it back out. Add engine oil if the liquid is at or below the lower limit. Take care not to add oil beyond the upper limit. After filling with oil, return the oil gauge to the oil receptacle and screw it back in place.

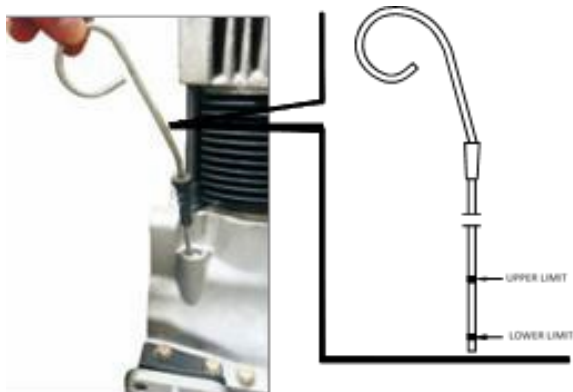

Use of proper lube oil preserves your engine

#### ENGINE OIL

We recommend the American Petroleum Institute (A.P.I.) classifications of CC or CD for optimum performance. Always use the oil with the right viscosity for the ambient temperature where your engine is being operated. Use the chart below for choosing your engine oil.

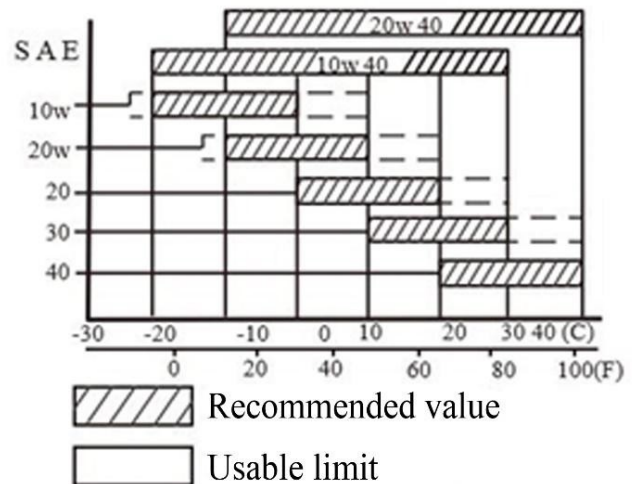

## ⚠ CAUTION

- Make sure your unit is on a flat surface when checking the oil level. If it is tilted, the gauge will be inaccurate.
- Overfilling can cause the engine to consume too much oil making the temperature dangerously high. Conversely, not having enough oil can cause your engine to seize up.
- To check the oil level, simply dip the dipstick into the filter neck. Do not screw in the dipstick.
- Be sure to check the engine on a level surface with the engine stopped.

### 3.2 Selecting and checking the fuel

- Only use light diesel fuel.
- When filling the fuel tank from the drums, make sure that no dust or water is mixed in the fuel. This may lead to serious fuel-injection pump and nozzle problems.

## ⚠ WARNING

- Refuel in a well-ventilated area with the engine stopped.
- Keep smoke, flames, or sparks away from fuel both when stored and refueling.
- Do not overfill the tank and make sure the fuel cap is closed securely after refueling.
- Be careful not to spill fuel when refueling. If any fuel is spilled, wipe the area dry before starting the engine.

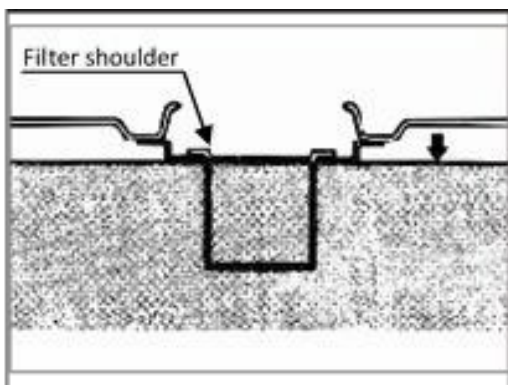

Overfilling is dangerous. Do not fill the tank beyond the top of the fuel filter shoulder.

- For PM13000D ES (Silent)

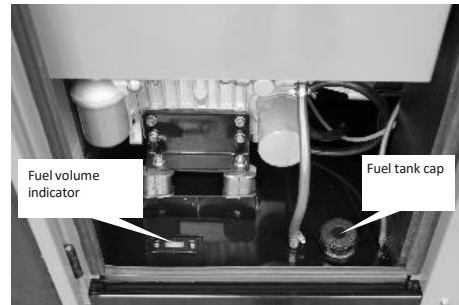

Open the left door, check the fuel volume indicator. If the fuel level is low, unscrew the tank cap, fill the fuel through the fuel filter. After filling fuel, screw back the tank cap.

### 3.3 Checking the battery

Check for any damage on the battery, specially the contact points. If dirty, corroded or loose: Clean and then tighten. If beyond repair, please replace the battery.

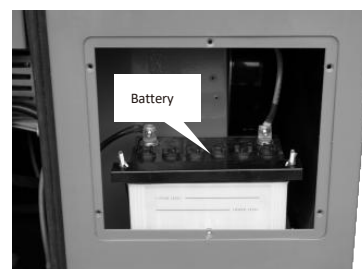
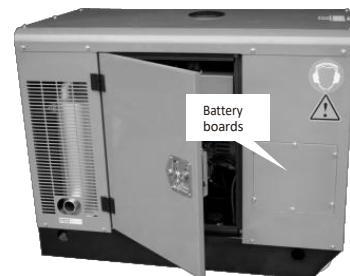

## 4. Starting Your Generator

### Starting

- Make sure there are no load connected to the generator
- Open the fuel cock (open type)
- Turn the starting key clockwise to "START" position.
- Remove your hand from the key as soon as the engine starts.
- If the engine does not start after 10 seconds, wait 30 seconds before trying to start it again.
- If the engine does not start after 3 attempts, check the battery or call Promate Service.

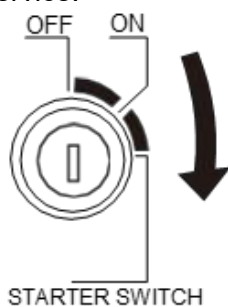

- If the starter is working for too long, the battery will go flat and the motor will seize up. Always leave the starting key at the "ON" position when the engine is running.

## 5. Operating Your Generator

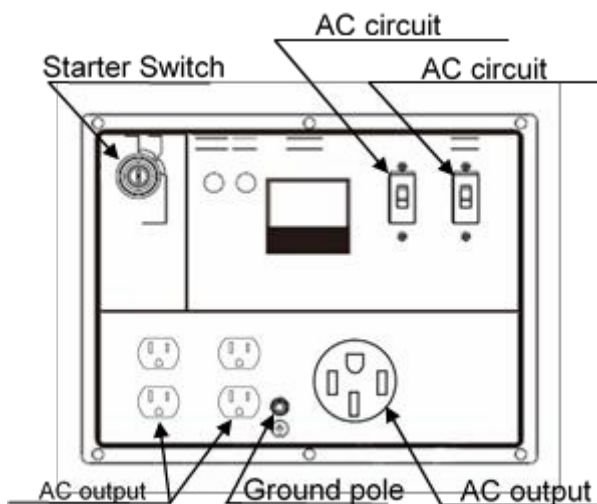

### 5.1 Operating your generator

- Let the engine run without load for 3 minutes.
- This generator is equipped with a low oil warning system. The engine will stop automatically in case of low oil pressure or a lubrication oil shortage. Check the oil level and refill if necessary.
- Do not loosen or adjust the engine speed limiting bolt or fuel injection limiting bolt. The generator performs best at factory settings.

### 5.2 Checks during operation

- Any abnormal sound or vibration?
- The engine misfiring or running rough?
- What about the color of the exhaust gas (is it black or too white)?

\*If you notice any abnormalities, discontinue use and contact your Promate Service immediately.

### 5.3 Loading your Generator

- Set AC circuit breaker to "ON". Pilot lamp will illuminate, the speed of generator must be at 220V-240V (can be seen on the volt meter on the control panel).
- Insert the plug of the appliance to be connected. Make sure they are switched off at the onset then switch them on one by one starting with motorized appliances (e.g. air conditioner) first followed by the inductive appliances (e.g. rice cooker, microwave) and finally small appliances (e.g. lights).

### ⚠ CAUTION

- Instruments which require high starting currents and some kinds of motors may not run even though they are rated within the limit of this generator. Please double check the STARTING current needed to start your appliance/device.
- The circuit breaker shuts "OFF" when the current exceeds the surge output limit or when the applied instrument is defective.
- The running current of the instruments should not exceed the rated current showed on the socket, or else it may damage the machine.

## 6. Stopping Your Generator Set

- a. Gradually turn off connected appliances starting with lights and ending with the motorized appliances (e.g. Aircon).
- b. Set the AC breaker to "OFF".
- c. Unplug the sockets of the electric appliances from the AC output port (or extension cord).
- d. Let the engine run for 3 minutes with no load.
- e. Turn off the generator by switching the starter key to the "OFF" position.

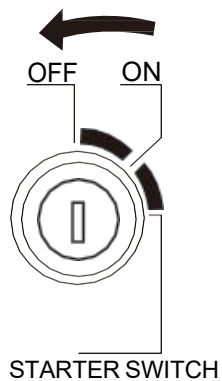

- f. Set the fuel cock to closed position. (open type)



## 7. Periodic checks and maintenance

Periodic checks and maintenance are very important for keeping the engine in good condition and will affect the durability of your unit. The mark ( ) indicates that special tools and skills are needed and you should contact Promate Service. Proper maintenance is not only the basis of safe, economical and trouble-free generator operation, but also helps reduce air pollution.

### WARNING

Shut off the engine before performing any maintenance. If the engine must run, make sure the area is well ventilated. The exhaust contains poisonous carbon monoxide gas.

Serious personal injury may ensue if the maintenance instructions are not followed properly.

### Maintenance Schedule

| Item \ Operation hours                       | Daily | First month                                      | Every 3 months          | Every 6 months         | Every year or |
|--|-------|--|-------------------------|------------------------|---------------|
|  |       | or 20Hrs   | or 100Hrs               | or 300Hrs              | every 1000Hrs |
| Check and tighten bolts and nuts             | ○     |  |                         |                        |               |
| Check and resupply engine oil                | ○     |  |                         |                        |               |
| Replace engine oil                           |       | ○ 1st time                                       | ○ 2nd time & thereafter |                        |               |
| Clean and replace oil filter                 |       |  | ○                       | ● Replace if necessary |               |
| Check oil leakage                            | ○     |  |                         |                        |               |
| Replace air cleaner element                  |       | Service more frequently when used in dusty areas |                         | ○                      |               |
| Drain the fuel tank                          |       | Monthly  |                         |                        |               |
| Clean and replace fuel filter                |       |  | ○ Clean                 | ○ Replace              |               |
| Check fuel injection nozzle                  |       |  |                         | ●                      |               |
| Check fuel injection pump                    |       |  |                         | ●                      |               |
| Check fuel piping                            |       |  |                         | ○ Replace if necessary |               |
| Adjust intake/ exhaust valves head clearance |       | ○ 1st time                                       |                         | ○                      |               |
| Check and lap intake/ exhaust valve seat     |       |  |                         |                        | ●             |
| Replace piston rings                         |       |  |                         |                        | ●             |
| Check battery liquid                         |       | Monthly  |                         |                        |               |

### 7.1.a Changing engine oil (PM13000D ES)

Place a container under the drain plug to catch the oil. Use a wrench to open the drain plug, then let the oil drain into a container. If there is any sediment or carbon on the inner rim or bottom of the tank, you may use diesel to wipe it clean. Screw back the drain plug.

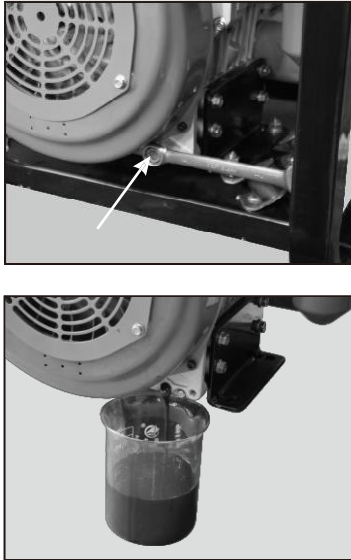

Open the lock over the front cover, screw the oil cap off as shown in the photo, pour the oil until reaching the limit of the oil gauge. Finally, screw back the cylinder head stud.

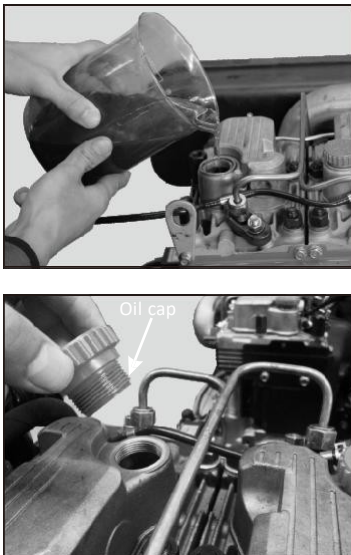

### 7.1.b Changing engine oil (PM13000D ES Silent)

Open the left door, use a wrench to release the drain plug (don't take out the screw), put the oil guide groove under the drain plug, make it align with the plug and a container then completely remove the drain plug. Let the oil drain out. If there is any sediment or debris on the inside of the receptacle use diesel to wipe it clean.

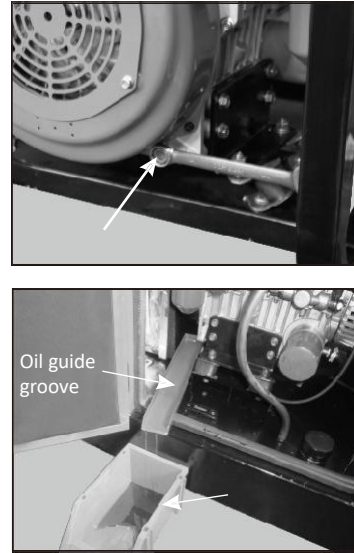

Open the lid on the top of generator, unscrew the oil cap then fill the oil until reaching the limit of the oil gauge. Finally, screw back the cylinder head stud.

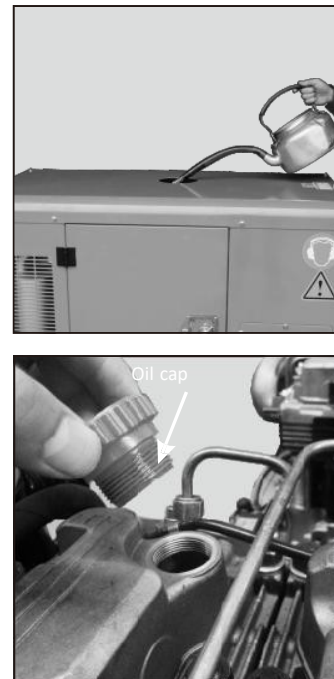

## 7.2 Cleaning the oil filter

Loosen the drain bolt and then pull out the oil filter. Clean every 3 months or 100 hours by spraying compressed air.

## 7.3 Cleaning and changing the air cleaner element

Wash the air cleaner element with diesel (do not use detergent/soap because this is a wet type element).

Remove side plate of the engine or open the lid of the generator to see the air cleaner. Release the clip, remove the lower part of the air cleaner and take out the filter element in the middle; wash the filter element with diesel fuel and put it back in the air cleaner after it is dry.



### **⚠ CAUTION**

Never run the engine without the element or with a defective element.

## 7.4 Long term storage & transport

### 1. Storage

Store the generator properly to keep the generator in good condition. These steps protect the generator from rust and corrosion and will make the generator start easier when the time comes to use it.

#### ① Cleaning

If the generator has just finished running, let it cool for 2 hours then clean the surface, paint damaged areas, and coat with a thin layer of plastic film, textile or fabric.

#### ② Fuel

Diesel fuel deteriorates during storage, which will make starting the generator more difficult and produce glue-like materials that can clog the fuel system. The fuel system will have to be replaced if the diesel fuel deteriorates during storage. To avoid this: make sure to drain the diesel from the tank before storing.

### 2. Storage instructions

① Do not touch the muffler. The exhaust pipe of the muffler becomes very hot while the generator is running and the heat will remain for some time after the generator stops. To prevent burns or fire: move the generator for storage after it is completely cooled.

② The storage room should be away from any fire hazards (e.g. kitchen, burners, dryers, etc.). The storage room should be dry to guard against rust and corrosion.

③ Keep the generator on a level surface as tilting may cause fuel or oil leaks.

### 3. Transport

① Make sure the generator is completely cooled during transport.

② Keep the generator on a level surface while shipping to prevent oil from leaking.

## 8. Specifications

| Model     |                    | PM13000D ES (Open)                  | PM13000D ES (Silent)             |                  |
|-----------|--------------------|-------------------------------------|----------------------------------|------------------|
| Engine    | Engine Model       | 290F                                |                                  |                  |
|           | Type               | Air cooled, 4-stroke, Twin-cylinder |                                  |                  |
|           | Bore               | mm                                  | 90                               |                  |
|           | Speed              | rpm                                 | 3600                             |                  |
|           | Max. Output        | hp                                  | 20                               |                  |
|           | Starting System    | Electric Start                      |                                  |                  |
| Generator | Type               | Brush/Brushless, AC Single Phase    | Brush/Brushless, AC Single Phase |                  |
|           | Frequency          | Hz                                  | 60                               |                  |
|           | Voltage            | V                                   | 230                              | 230              |
|           | Rated Output       | kVA                                 | 10.4                             | 10.4             |
|           | Max Surge          | kVA                                 | 13                               | 13               |
|           | Power Factor       |                                     | 1.0                              | 1.0              |
|           | Fuel Tank Capacity | L                                   | 25                               | 50               |
|           | Duration of full   | h                                   | ≤5.0                             | ≤11.5            |
|           | Fuel Consumption   | g/kwh                               | ≤350                             |                  |
|           | Size (LxWxH)       | mm                                  | 910 x 578 x 668                  | 1160 x 675 x 945 |
|           | Net Weight         | kg                                  | 170                              | 295              |

## 9. SERVICE INFORMATION

### HOW TO ORDER REPLACEMENT PARTS

Even quality-built equipment such as the generator you have purchased will need occasional replacement parts to maintain its good condition over the years.

To order replacement parts and consumable parts, please contact Promate Service (details below) and be ready with the following information:

1. Model No., Serial No. and all specifications that are shown on the Model No./Serial No. plate.
2. Part number or numbers as shown in the Parts List section.
3. A brief description of the trouble with the generator.

### LIMITED WARRANTY

Warranty Coverage: Powertech Asia Pacific Inc., (the Company) warrants to the original retail customer that it will repair or replace, free of charge, any parts found by the Company or its authorized service representative to be defective in material or workmanship. This warranty covers the cost of replacement parts and labor for defects in material or workmanship.

#### Not Covered:

- Shipping/Handling charges for sending the product to the Company or its authorized service representative for warranty service. Shipping/Handling repaired or replaced products back to the customer; these charges must be borne by the customer.
- If a separate operator's manual and engine warranty from the engine manufacturer is included with this product, only that warranty will apply to the engine.
- Damage caused by abuse, accident, the effects of corrosion, erosion and normal wear and tear.

- Warranty is void if the customer fails to install, maintain and operate the product in accordance with the instructions and recommendations of the Company set forth in the owner's manual, or if the product is used as rental equipment.

- The Company will not pay for repairs or adjustments to the product, or for any costs of labor performed without the Company's prior authorization.

- Consumable parts such as battery, spark plugs, and air cleaner.

Warranty Period: One (1) year from the date of purchase on products used solely for consumer applications; if a product is used for business or commercial applications, the warranty period will be limited to ninety (90) days from the date of purchase.

For warranty service, the customer must provide dated proof of purchase and must notify the Company within the warranty period.

**EXCLUSIONS AND LIMITATIONS: THE COMPANY MAKES NO OTHER WARRANTY OF ANY KIND, EXPRESS OR IMPLIED. IMPLIED WARRANTIES, INCLUDING WARRANTIES OF MERCHANTABILITY AND OF FITNESS FOR A PARTICULAR PURPOSE, ARE HEREBY DISCLAIMED. THE WARRANTY SERVICE DESCRIBED ABOVE IS THE EXCLUSIVE REMEDY UNDER THIS WARRANTY; LIABILITY FOR INCIDENTAL AND CONSEQUENTIAL DAMAGES IS EXCLUDED TO THE EXTENT PERMITTED BY LAW.**

This warranty gives you specific legal rights, and you may also have other rights which vary from state to state. Some states do not allow a disclaimer of implied warranties or the exclusion or limitation of incidental and consequential damages, so the above disclaimers and exclusions may not apply to you.



**CONTACT THE POWERTECH Asia Pacific Inc.,**

PRODUCT SERVICE DEPARTMENT AT (+632) 984 2620 | 09228741679

service@powertechasiapacific.com

www.facebook.com/PromateServicePH/

(MAIN) #420 Diamond Warehouse Compound, F Legaspi St., Maybunga Pasig City 1607  
(DAVAO) Space 10 & 11 Jin-Long Complex R. Castillo St., Agdao District, Davao City 8000

